

HORIZONTAL CNC PALLET TABLE ACC

Auto Pallet Changer

- ◆ Shorten the time of workpiece setting.
- ◆ The pallets can be flexibly increased.
- ◆ Increase the production efficiency.



Model No. : ACC-500

Auto Pallet Changer
Table Size 500×500

Item/Model No.	ACC-400	ACC-500	ACC-630	ACC-800
Table Dimension(L*W)	min/inch 400x400/15.75	500x500/19.69	630x630/24.80	800x800/31.50
Method of Rotating	Hydraulic Rack	Hydraulic Rack	Hydraulic Rack	Hydraulic Rack
Swing Diameter	min/inch ϕ 1450/57.09	ϕ 1553/61.14	ϕ 2100/82.68	ϕ 2350/92.52
Distance of the Center Point of Two Pallets	min/inch 1000/39.37	900/35.43	1300/51.18	1500/59.06
Ascending and Descending Travel of the Pallet	min/inch 80/3.15	55/2.17	80/3.15	80/3.15
Lifting Force (Hydraulic/60kg/cm ²)	kgf 5400~7600	5400~7600	8000~12000	9000~15000
Rotating Force (Hydraulic/60kg/cm ²)	kgf 2000	2000	3000	4000
MAX. Work Load	kg 500	600	1200	2000
N.W. of Table	kg 80	80	120	150
N.W. of Pallet Changer	kg 350	350	500	650
The Load Limit of Two Pallets	kg 350	420	840	1400
Exchange Time	sec. 13	14	22	25

- ◆ GANRO has right to revise the above specifications. We also can revise the specifications for customers' special requirement.
- ◆ Rotation method also can be driven by motor according to customers' requirements.

CNC HORIZONTAL PALLET TABLE

ACC-400

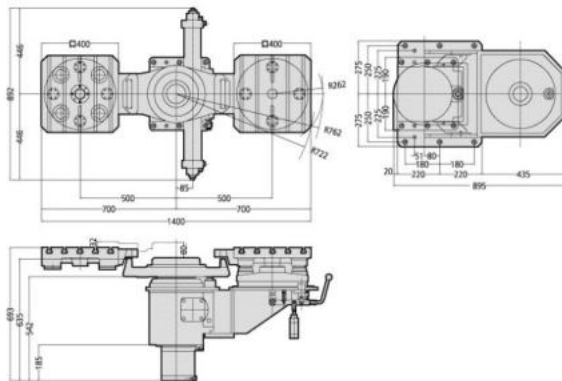

ACC-500

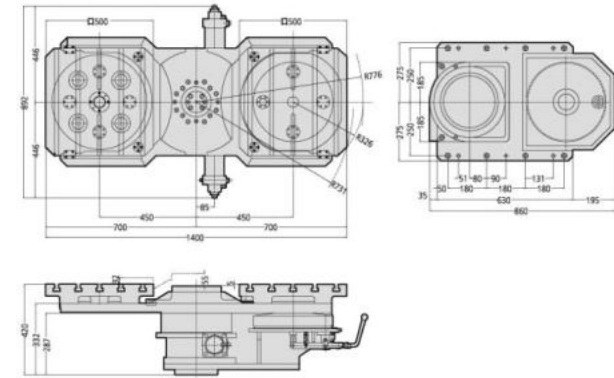

ACC-630

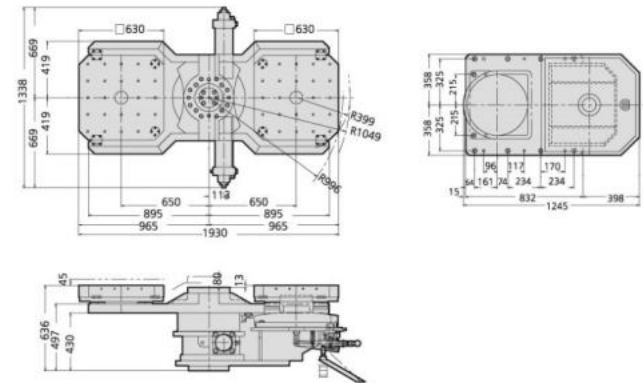

ACC-800

